

Presentation of

**Ursa Major Autumn School 2022
(Urban Sustainability in arctic Cities)**

&

Levende Abels gate festival 2022

Mahgol Afshari

Project manager/Advisor

Section mobility

Trøndelag Fylkeskommune



13th December

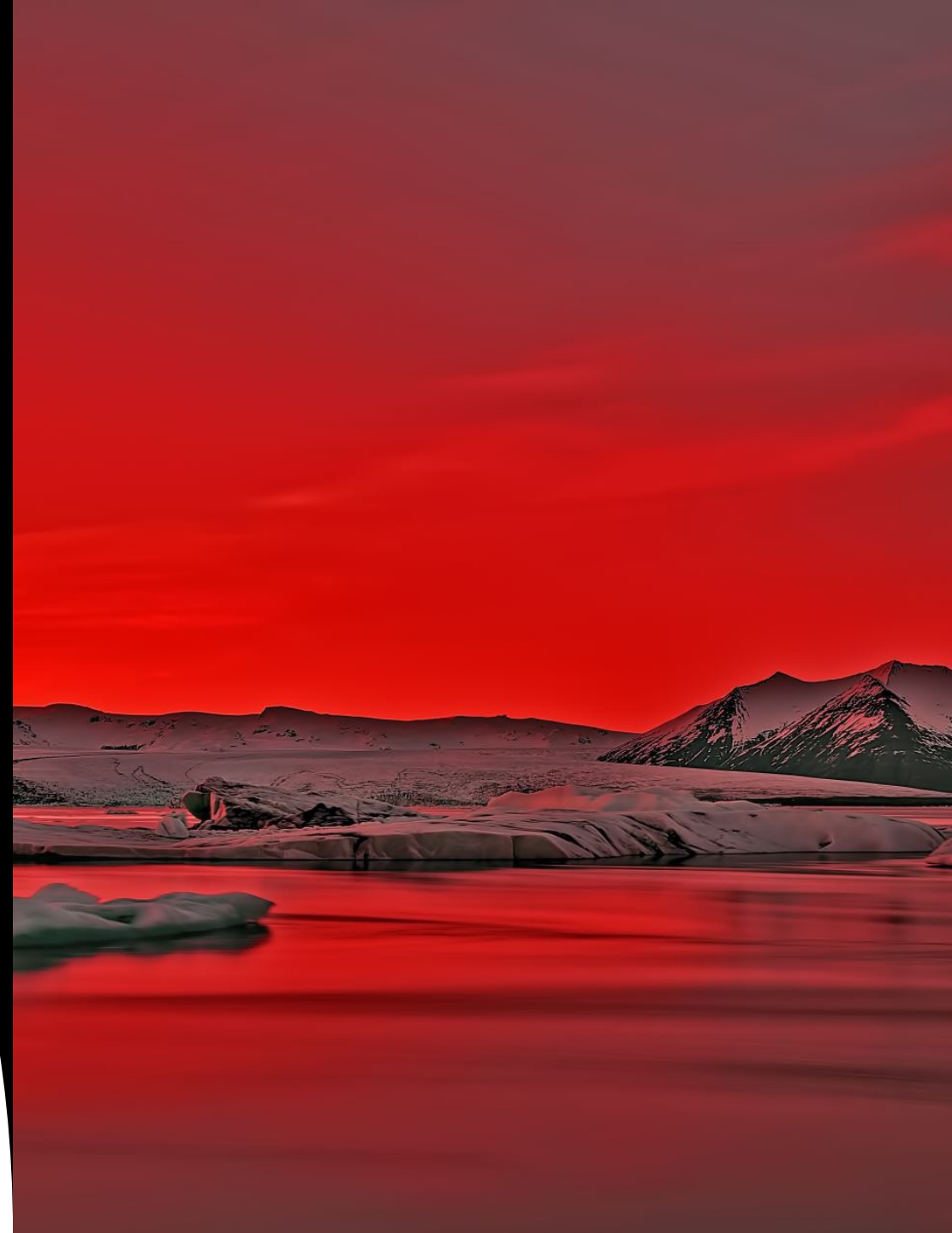

Ursa Major Autumn School 2022 (Urban Sustainability in arctic Cities)

Elgeseter gate - project

Aim:
Increasing active mobility with biking

The group members



Susanna Hsu Hals
NTNU - Trondheim
Sivil Engineering



Hermanni Hakumäki
University of Oulu
Architecture



Vilja Halonen
University of Oulu
Architecture



Eljas
University of Oulu
Architecture



Konsta Anastasiou
University of Turku
Social Science



Pradipta Banerjee
NTNU - Trondheim
Computer Science



Sara Rajala
University of Oulu
Architecture



Oona Kivialho
University of Eastern
Finland - Kuopio
Social science



Alenka Temeljotov-Salaj
alenka.temeljotov-salaj@ntnu.no



Mahgol Afshari
mahaf@trondelagfylke.no



Miljøpakken
- åpner nye muligheter

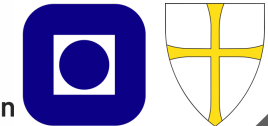



High density of student residents



High density of people in general

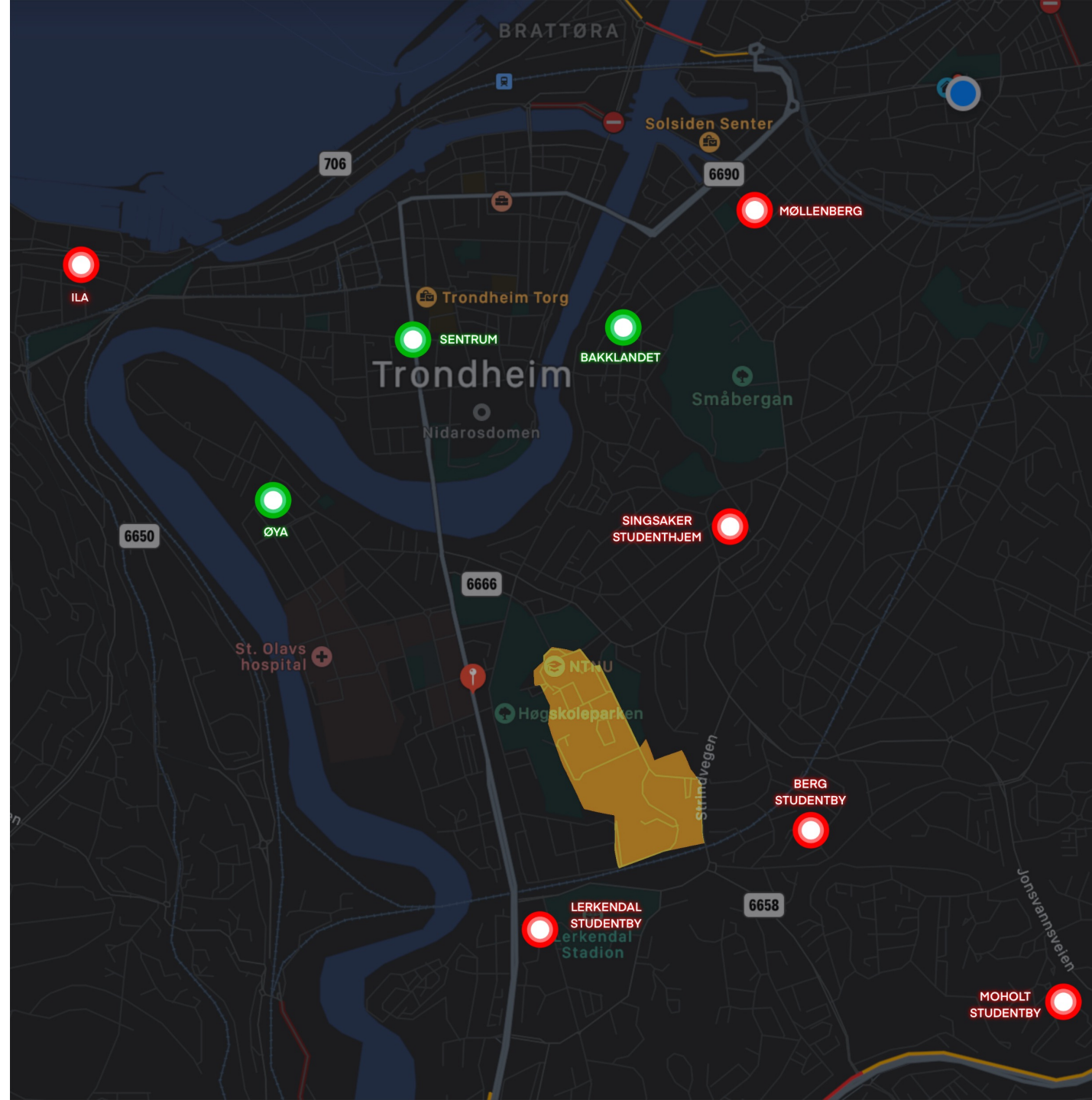



Already existing bicycle roads/lanes

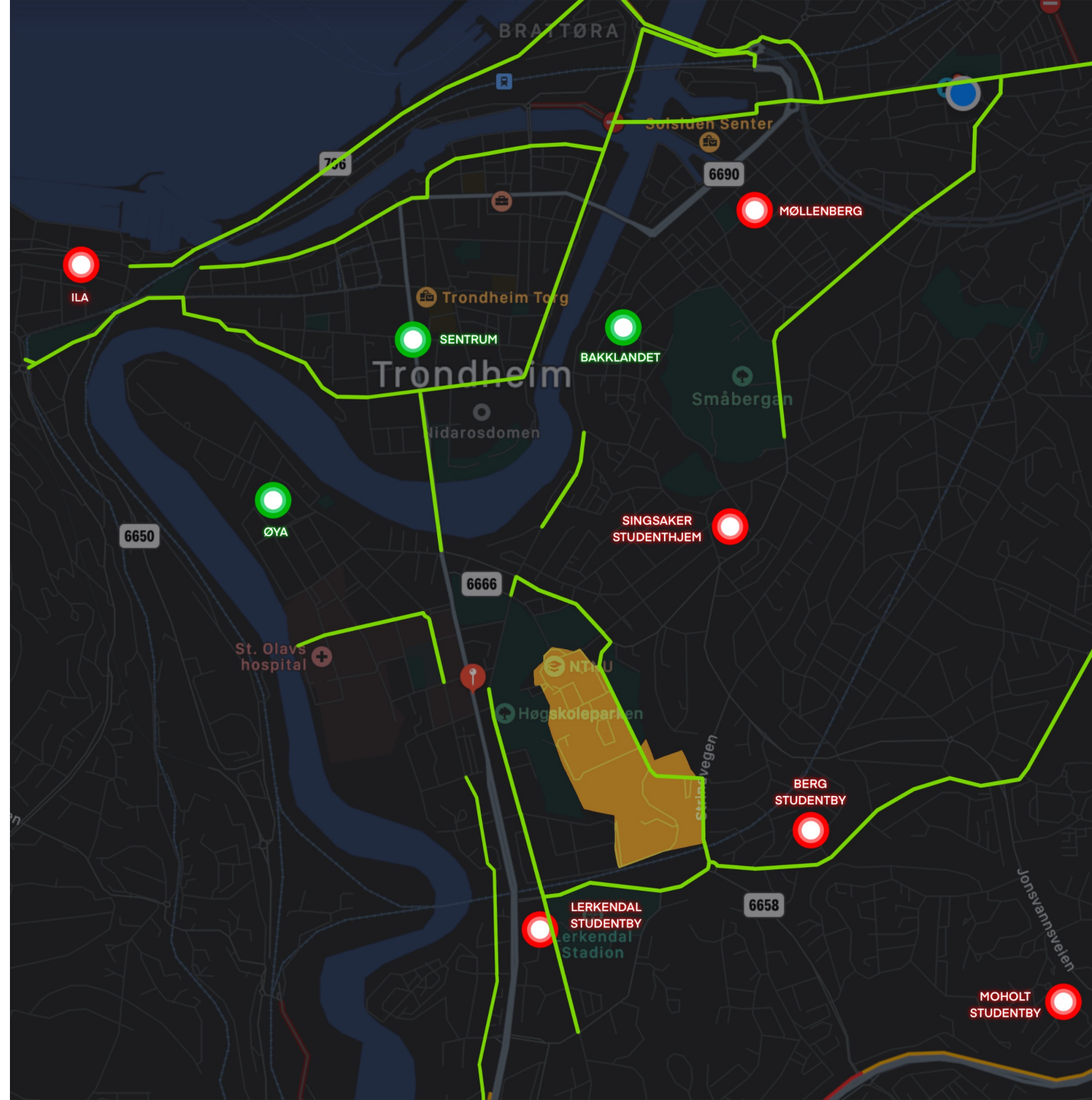



Already existing bicycle roads/lanes



Roads that should be practical for biking

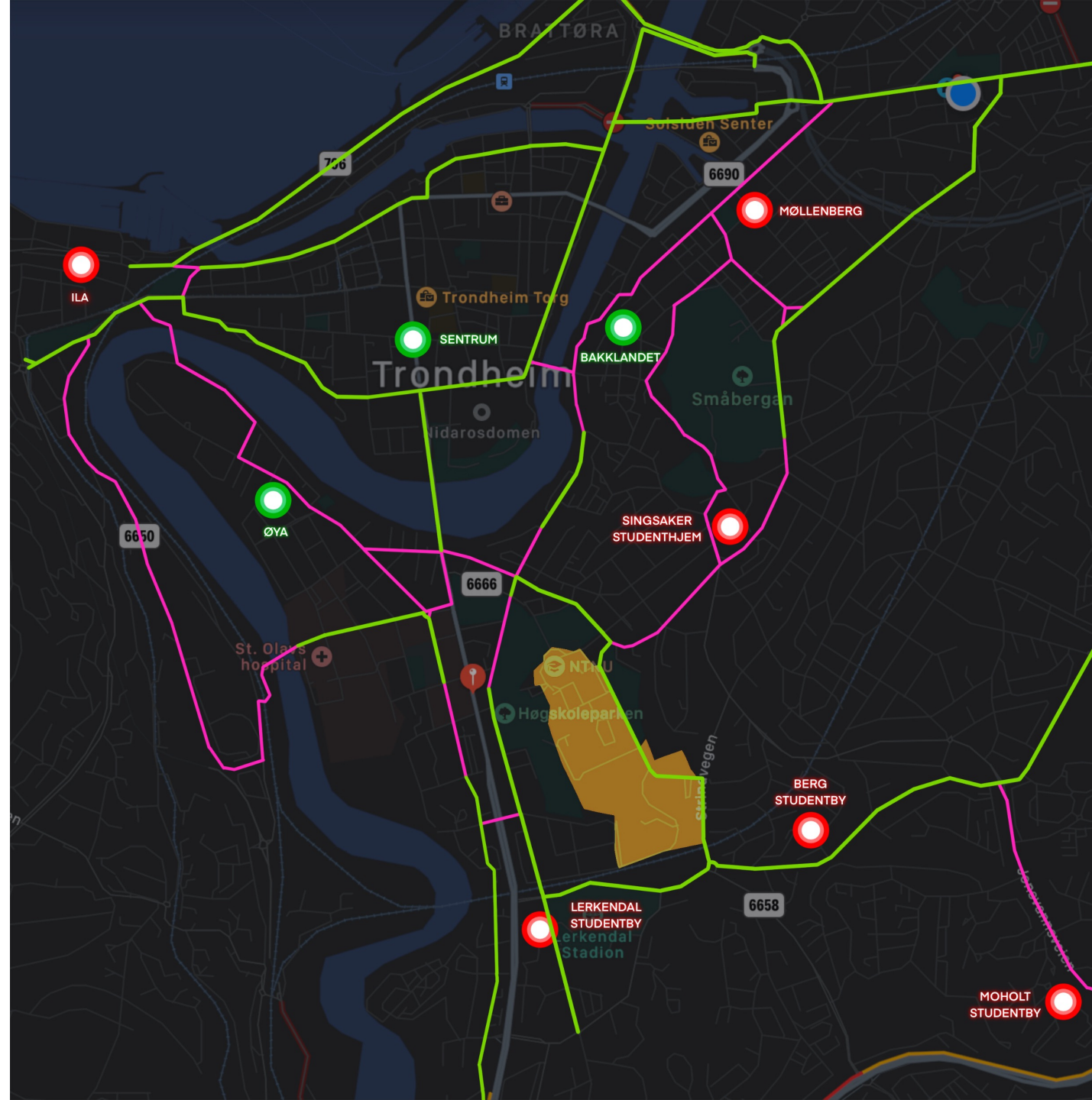



Already existing bicycle roads/lanes



Roads that should be practical for biking



Roads that are okay for biking

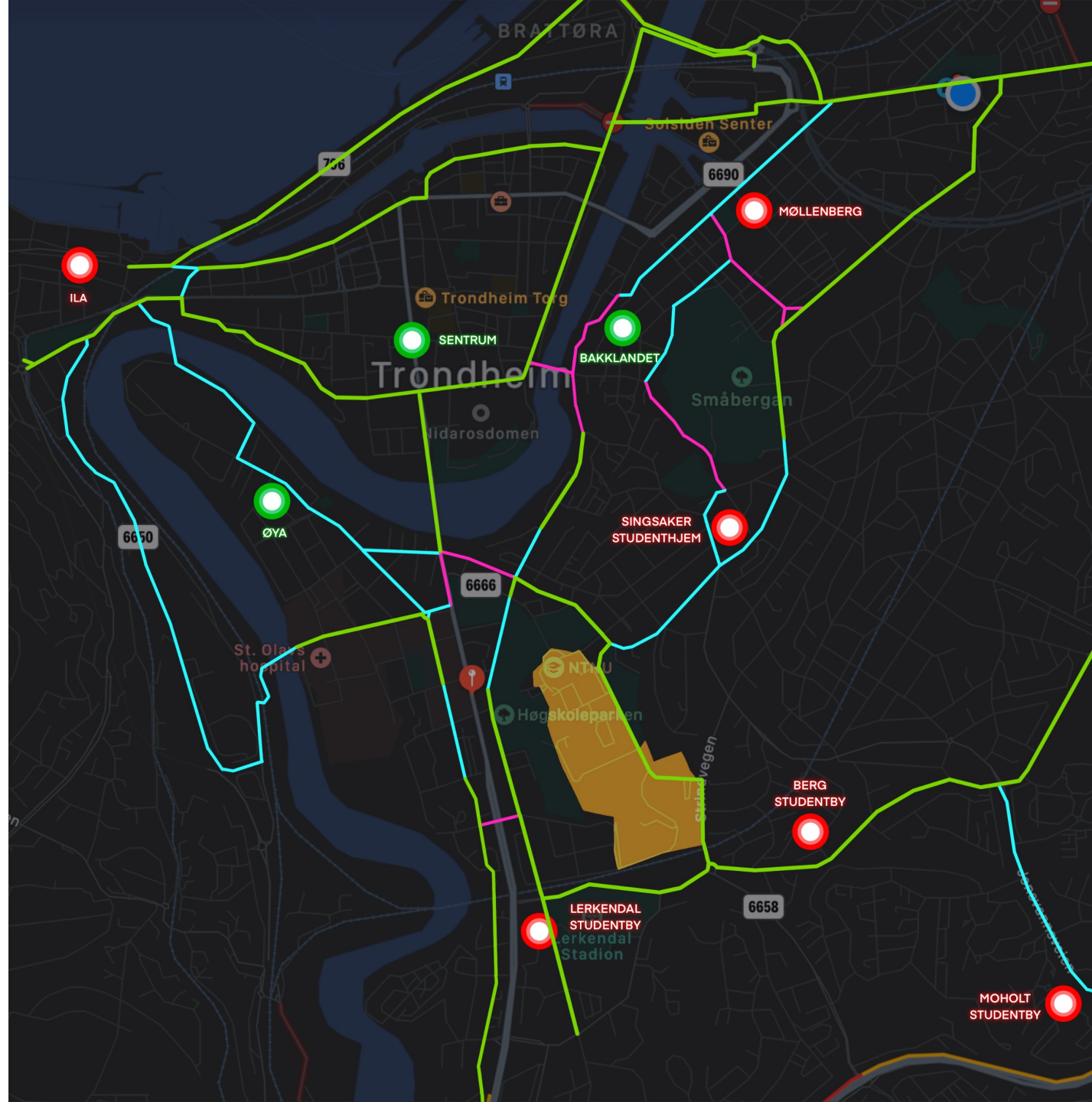



Already existing bicycle roads/lanes



Roads that should be practical for biking



Roads that are okay for biking

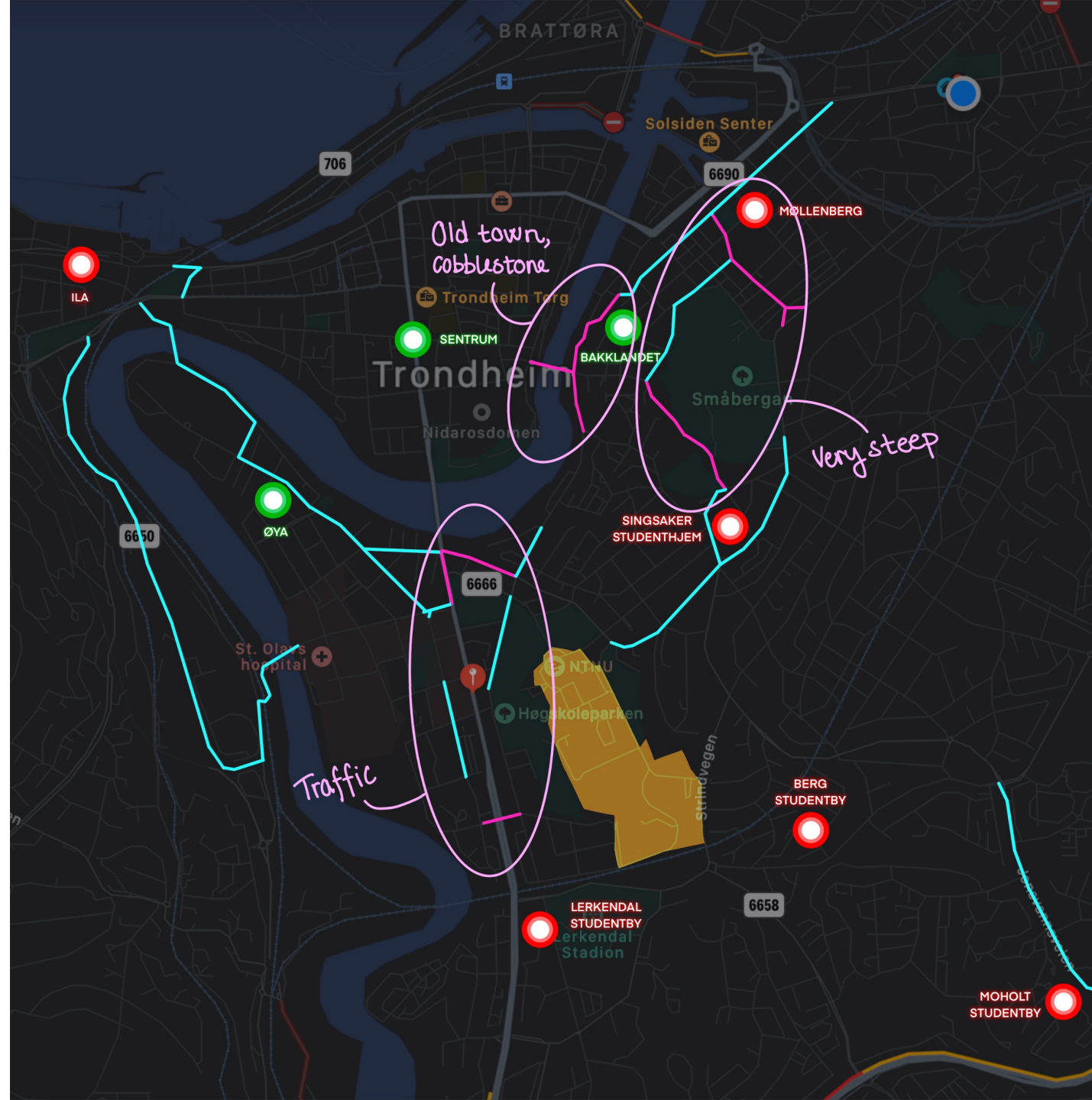



Already existing bicycle roads/lanes



Roads that should be practical for biking



Roads that are okay for biking



Bicycle hotels

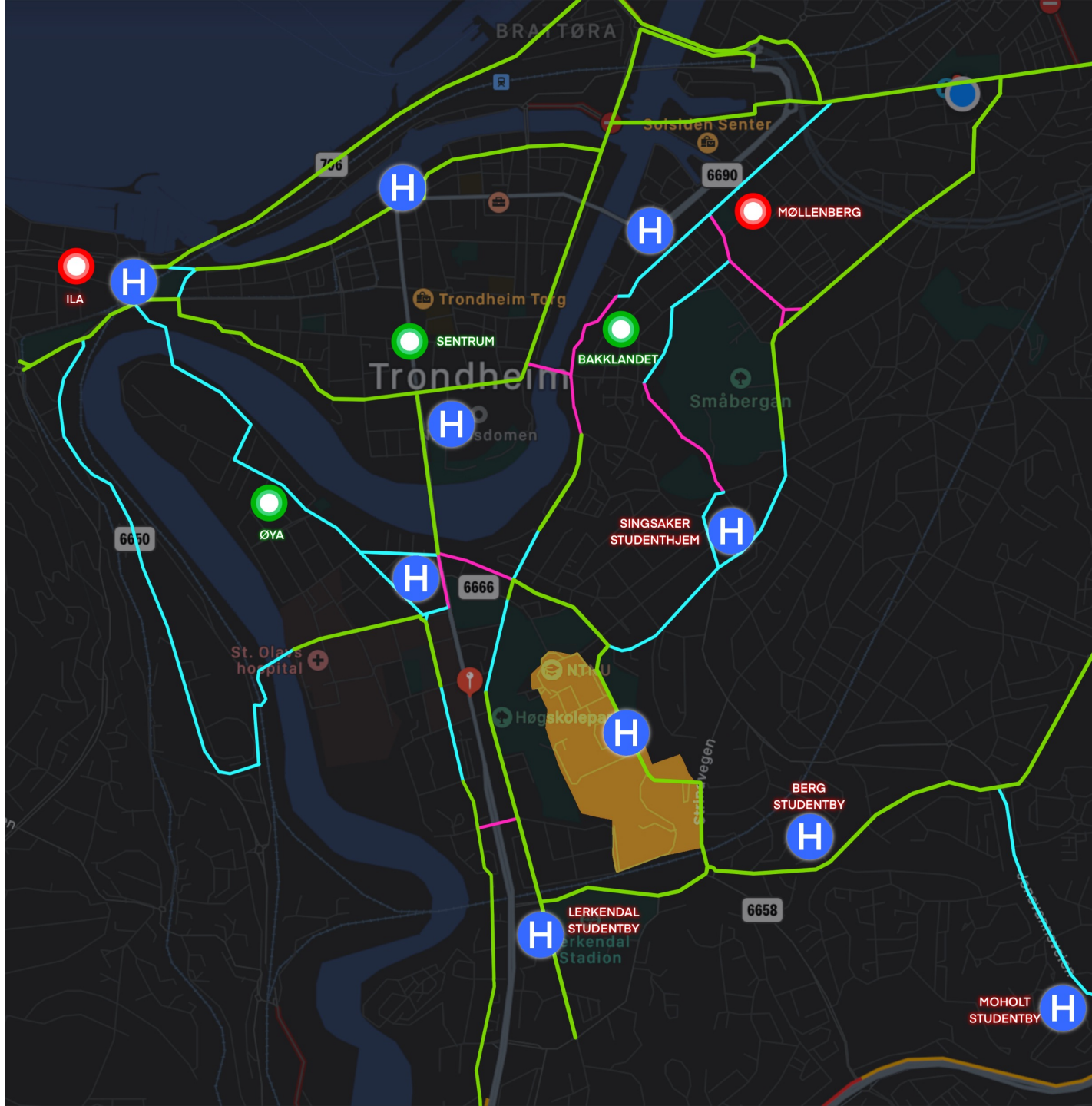



Shvekkel

— Den beste hverdagssykkel —



APPROACHABLE



USEFUL



SUSTAINABLE



ACCESSABLE



POSITIVE IMPACT
ON SCENERY



COOLNESS

PROPOSED SOLUTIONS

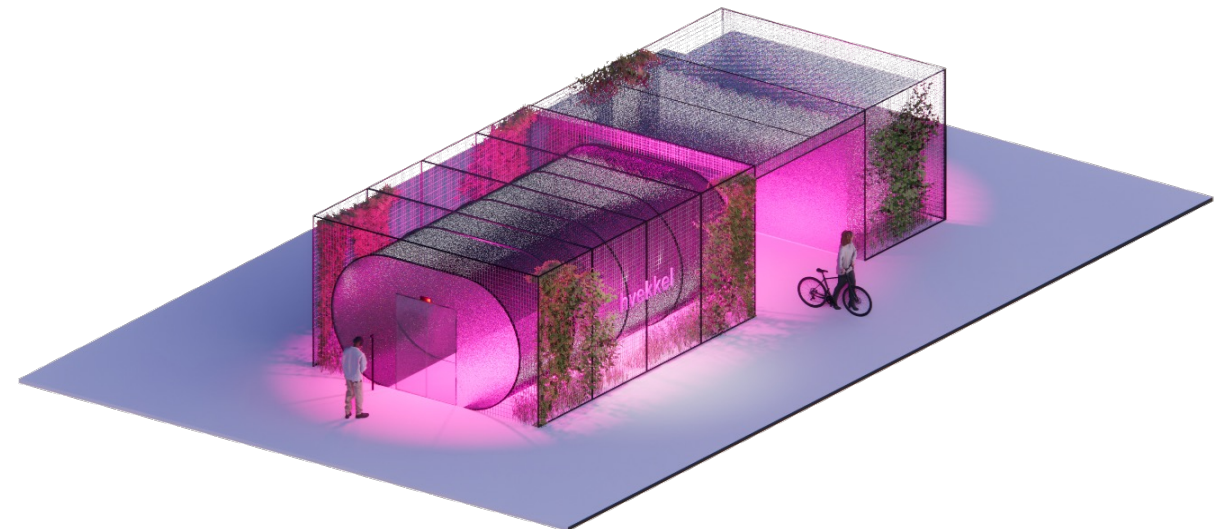

THE BIKE

Problems with city bikes

- Poorly adjustable, City bikes are not for everyone
- Lack of elegance
- City bikes are too heavy to ride
- Not available for all year around



hvekkel - Concept bike

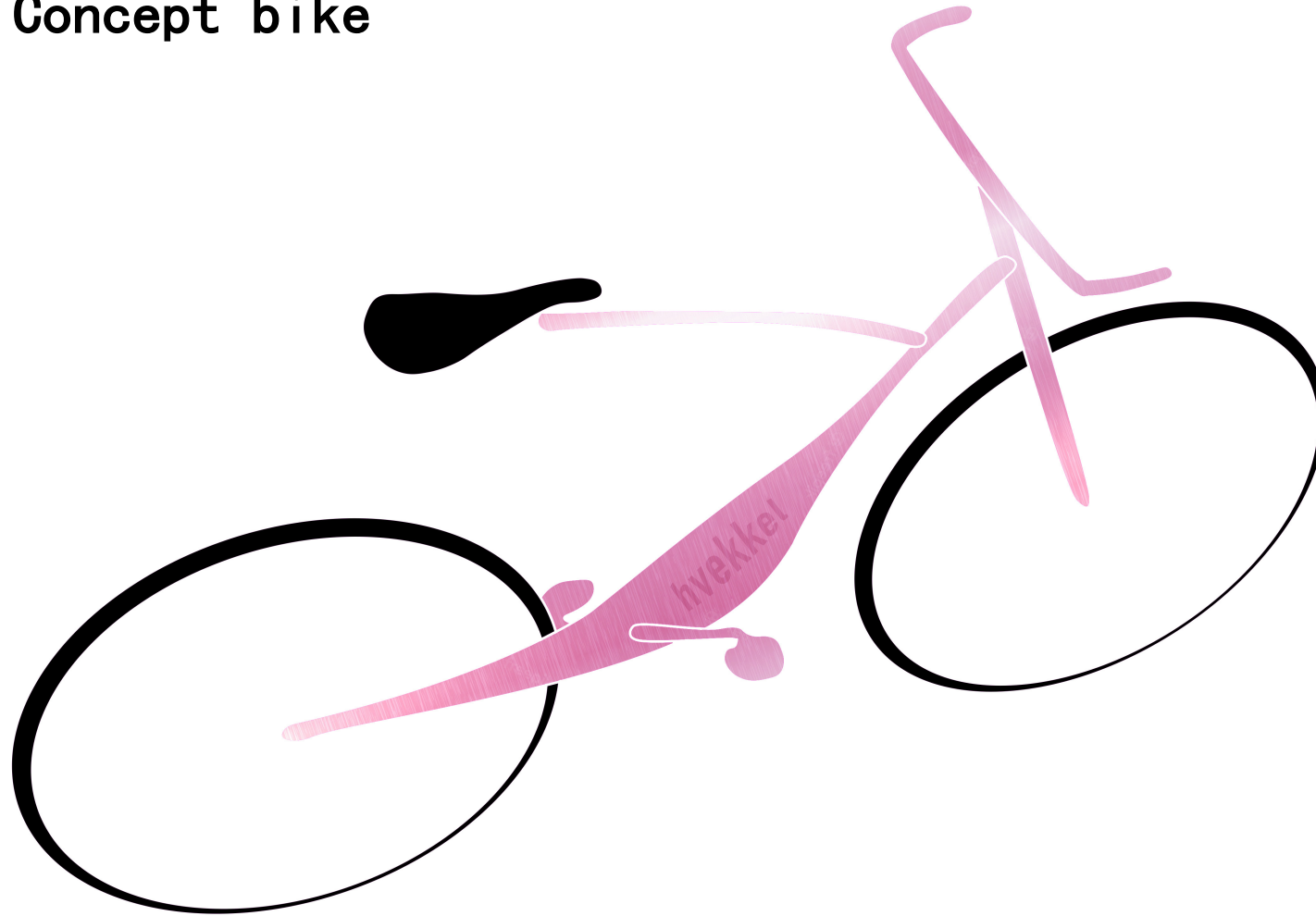

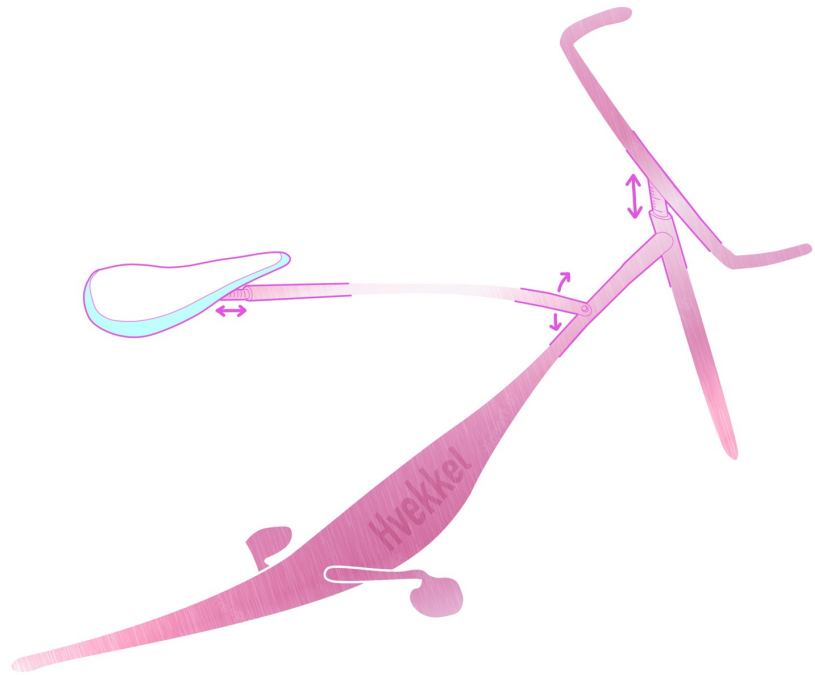

Adjustable core

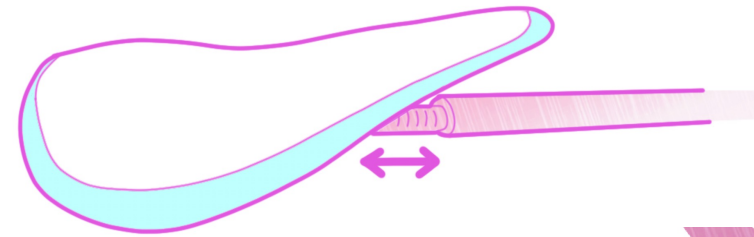
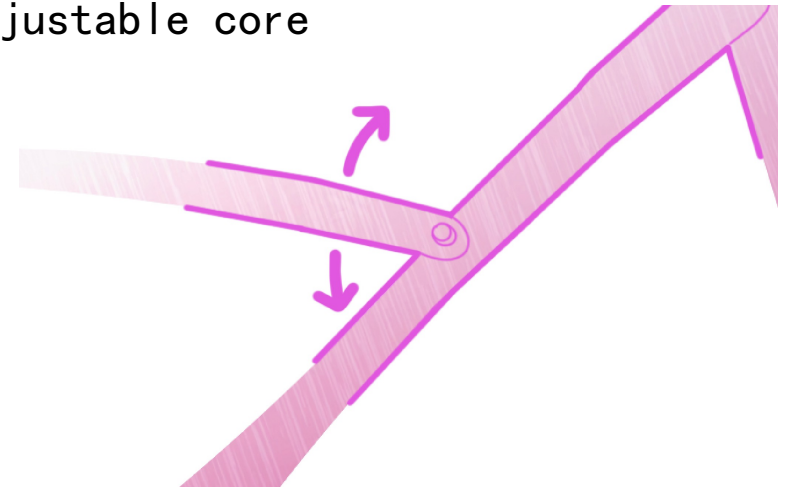

Adjustable saddle

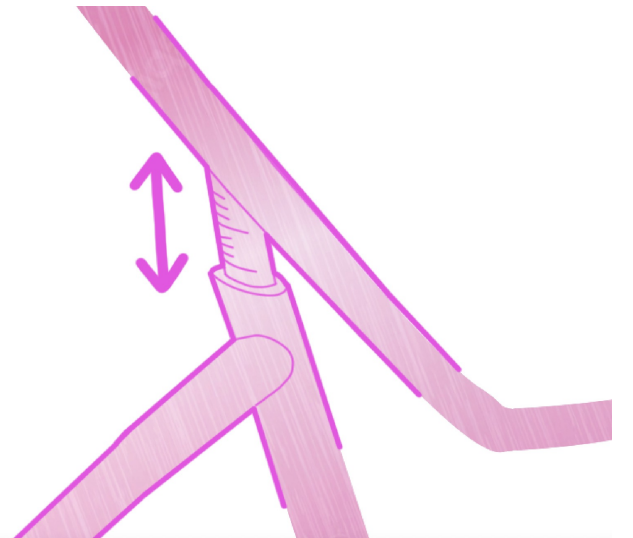

Adjustable handlebar

THE BIKE HOTEL

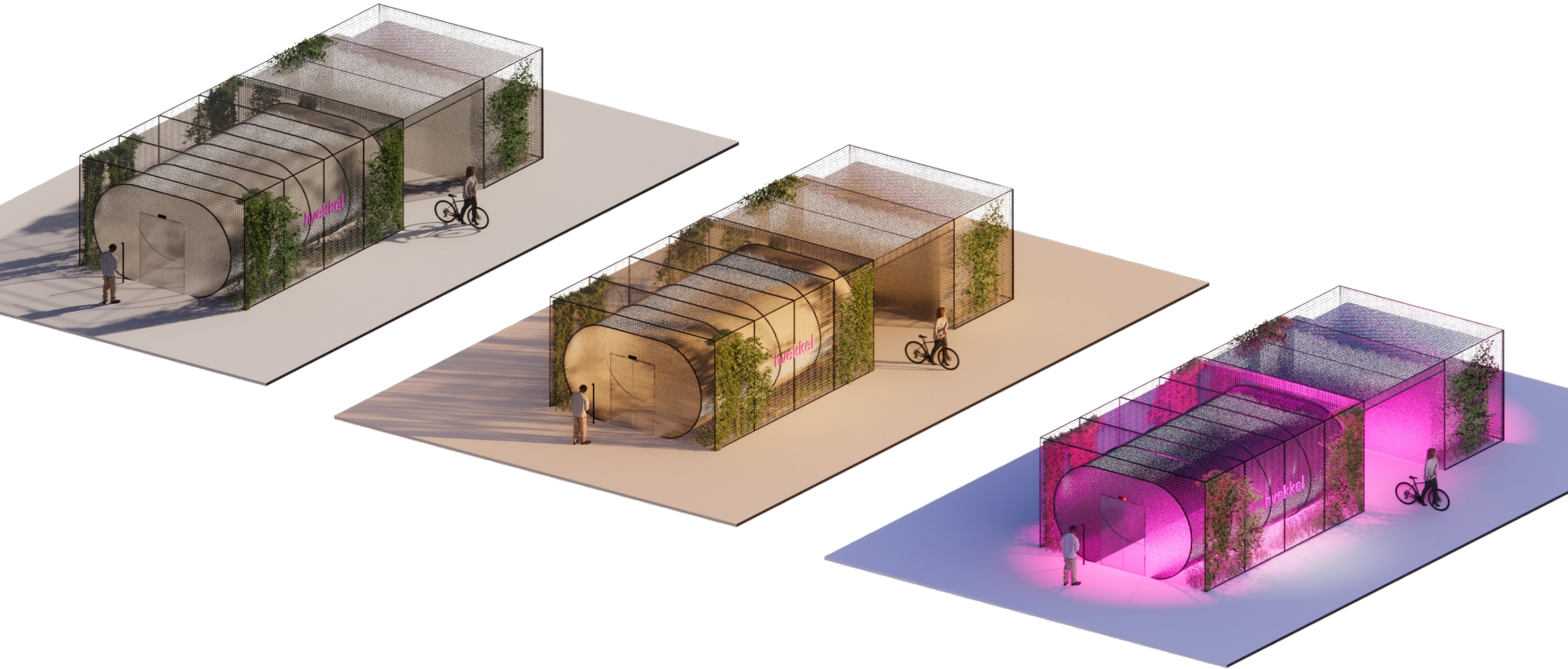

MOST



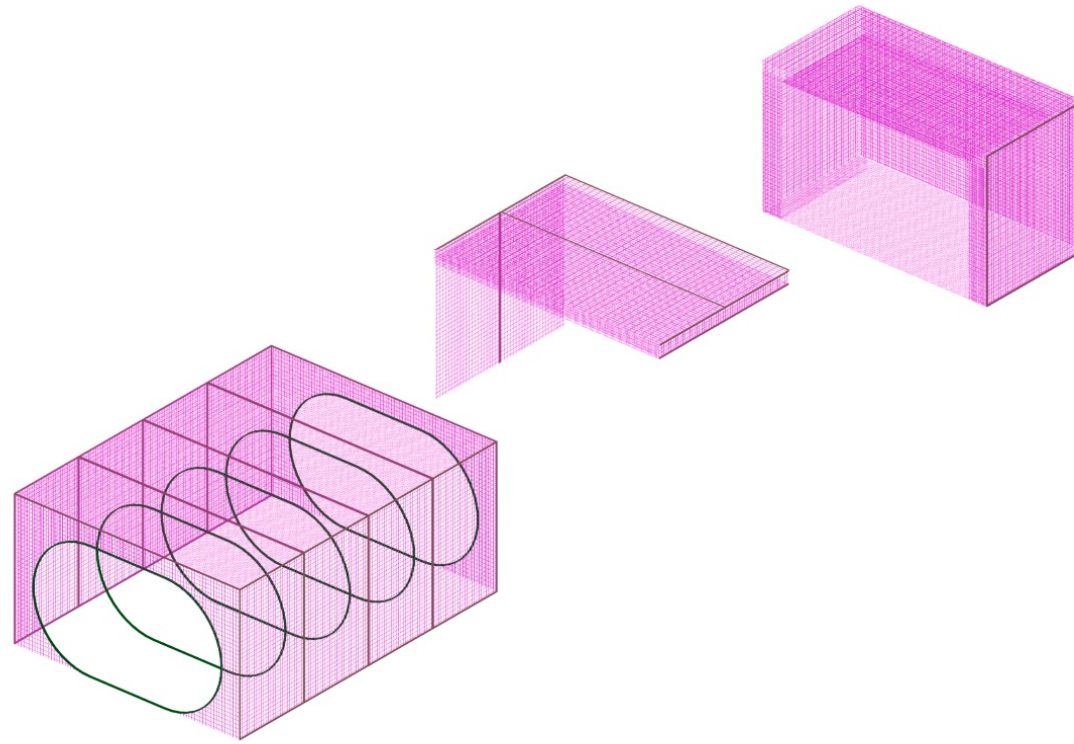

Function of the bike hotel

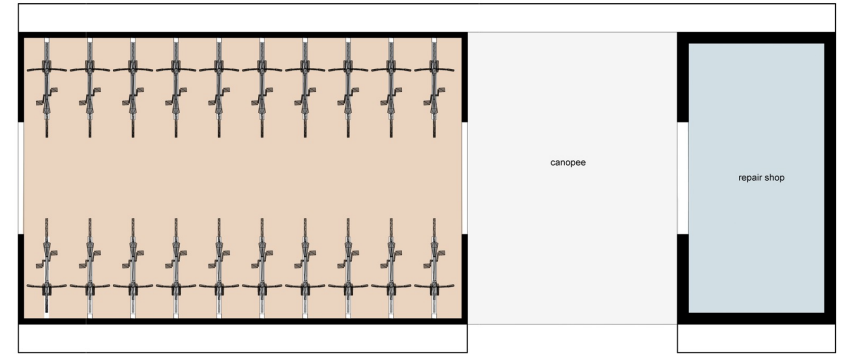
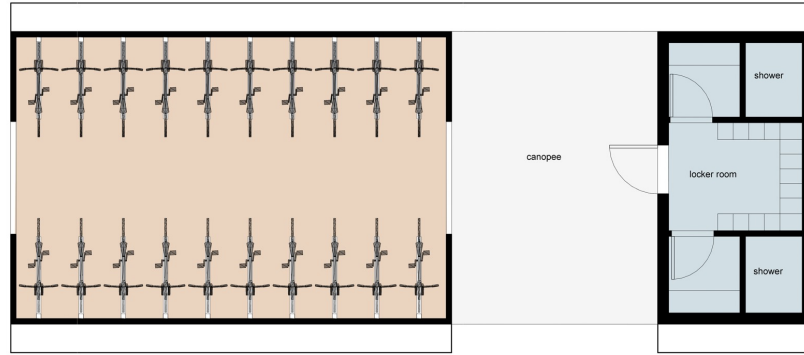
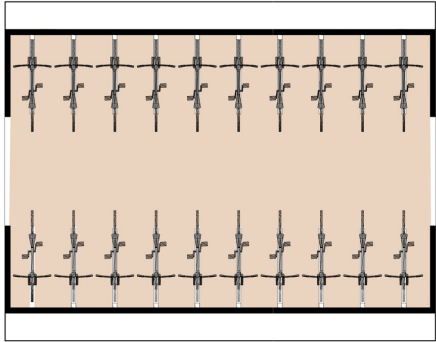

Different kind of bike hotel units



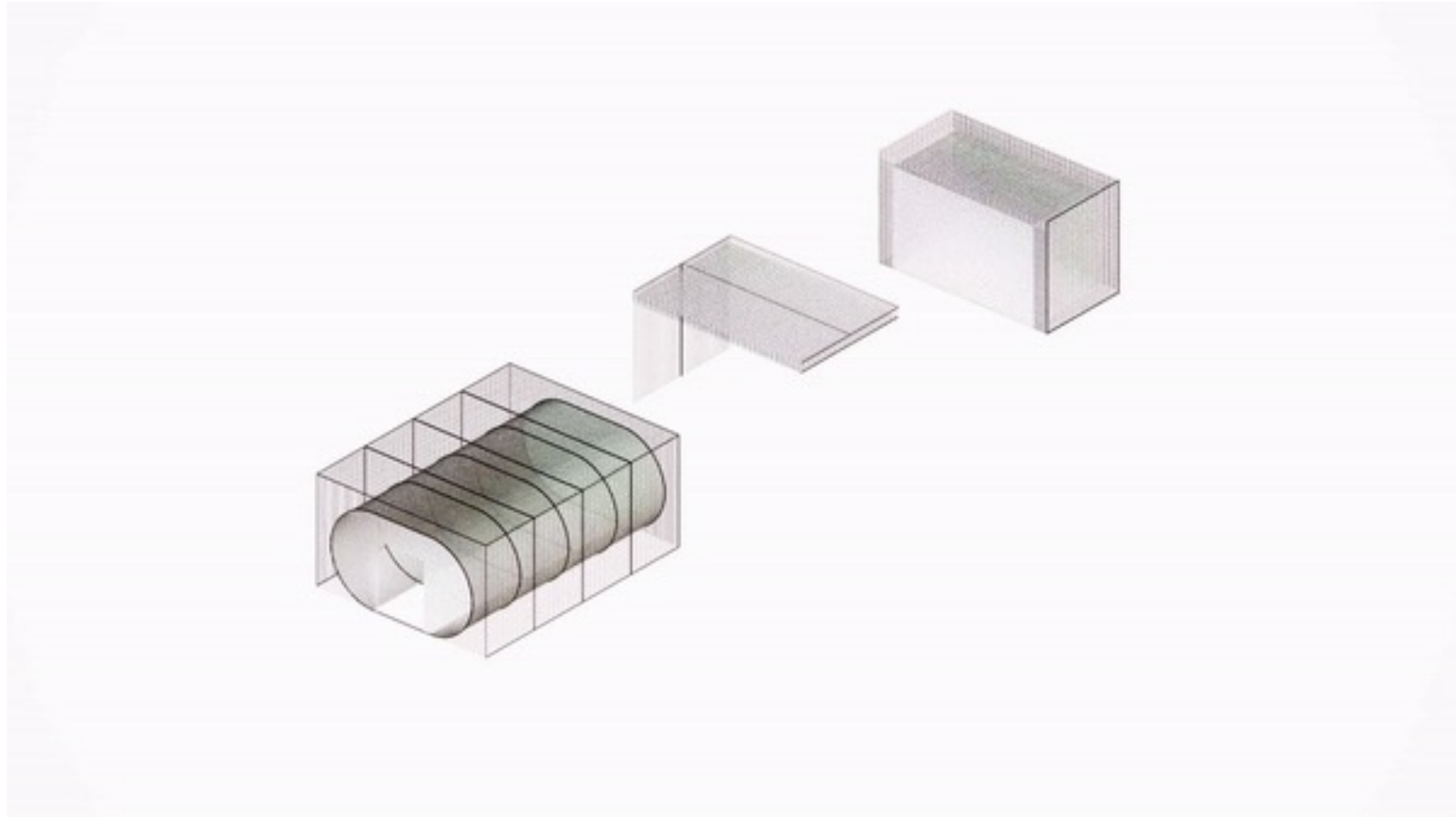

Aim for zero emission - Solar panels

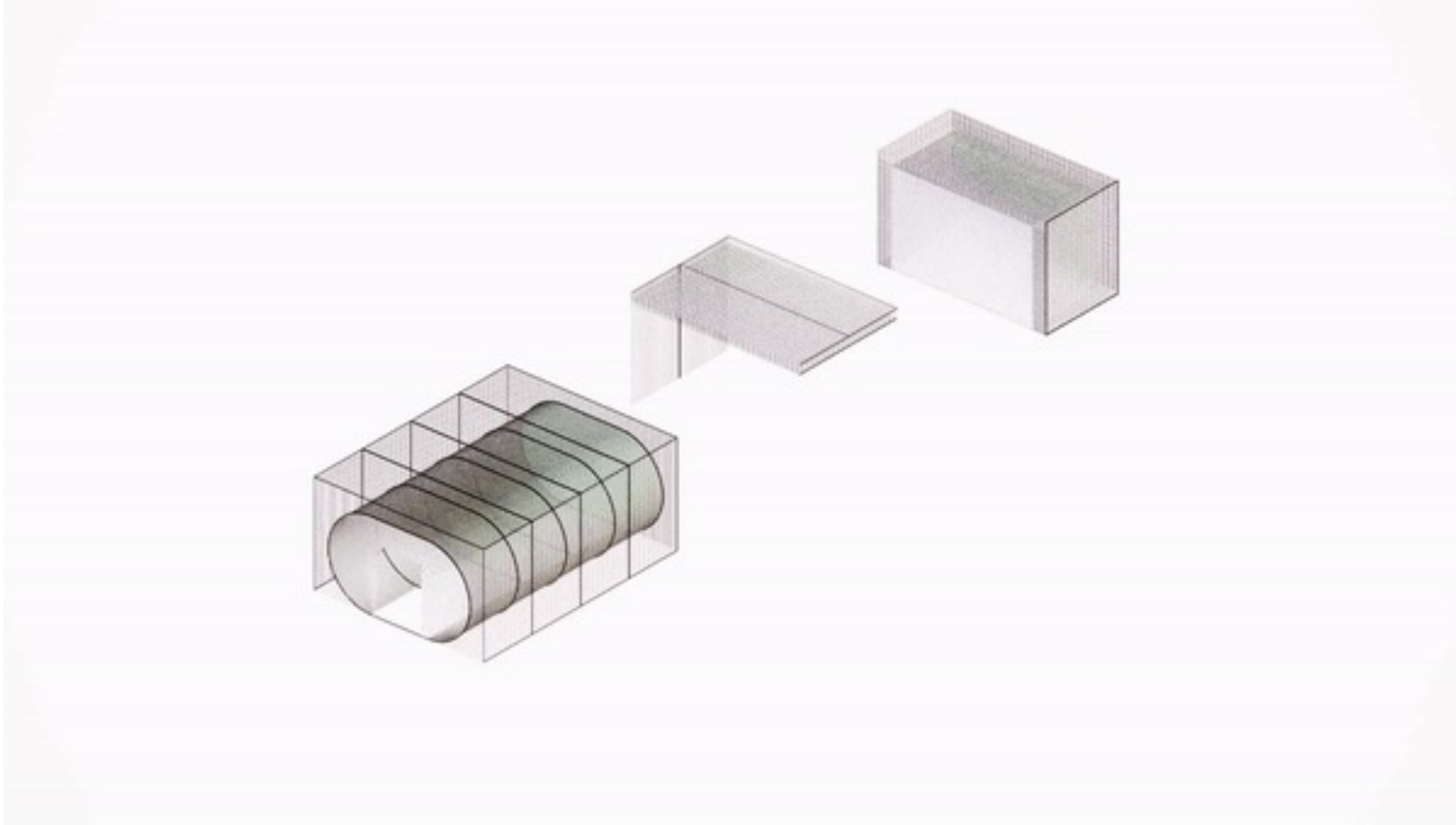

Aim for zero emission - Water recycle

THE APPLICATION

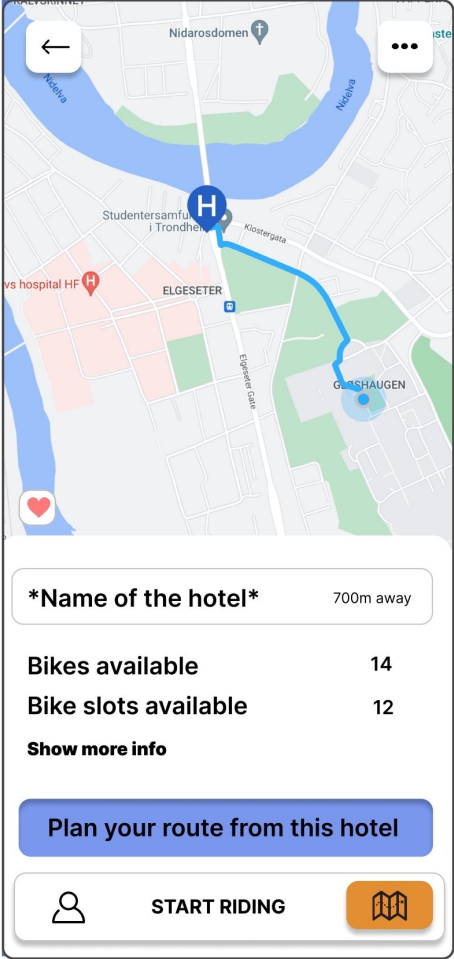
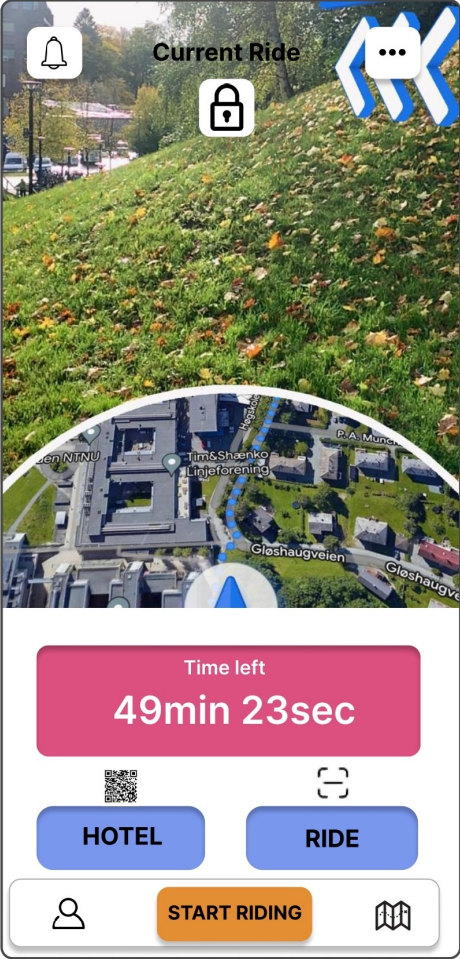

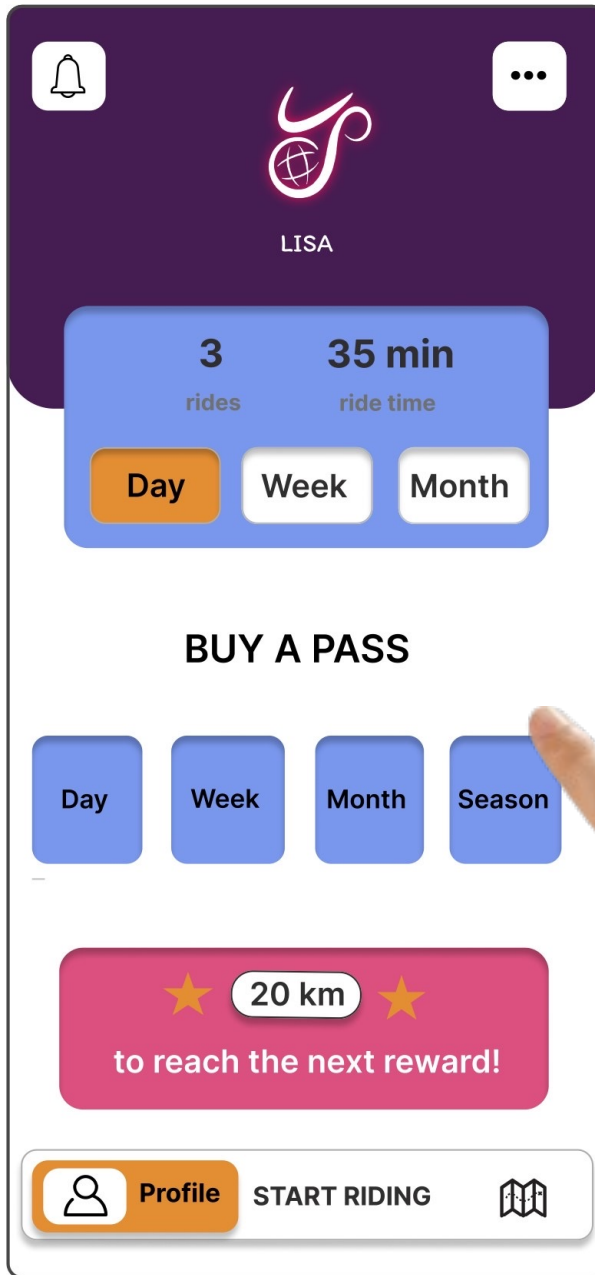

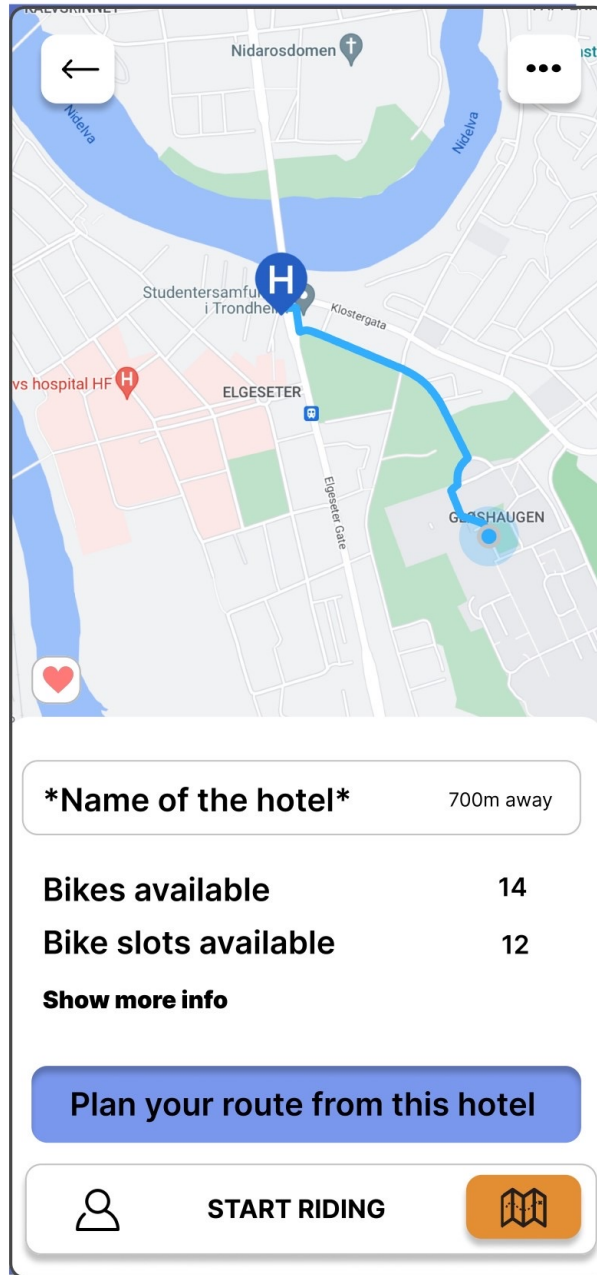

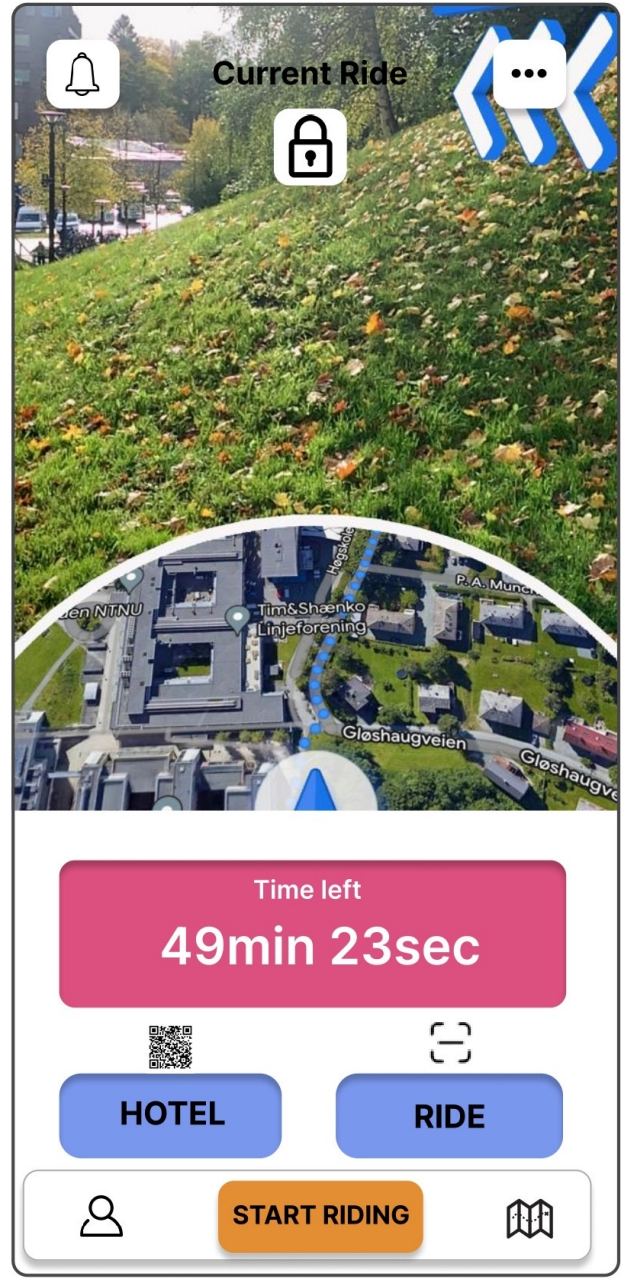



hvekkel

hvekkel

Levende Abels gate festival

- 4th September 2022
- Morning to evening
- Both indoors and outdoors
- 1500-2000 people



Aims to

- Create life at Elgeseter
- Sustainable urban development
- Citizen involvement



Project manager:

Mahgol Afshari
mahaf@trondelagfylke.no

Photos by Javad Montazeri

PADRIV



Miljøpakken
- åpner nye muligheter

MOST



NTNU

Norwegian University of
Science and Technology



Trøndelag fylkeskommune
Trööndelagen fylkhkentjئےle



Photos by Javad Montazeri



Thanks for your attention!

Questions? mahaf@trondelagfylke.no